

# WHAT THEY DIDN'T TEACH YOU IN ENGINEERING SCHOOL ABOUT HEAT TRANSFER

White Paper

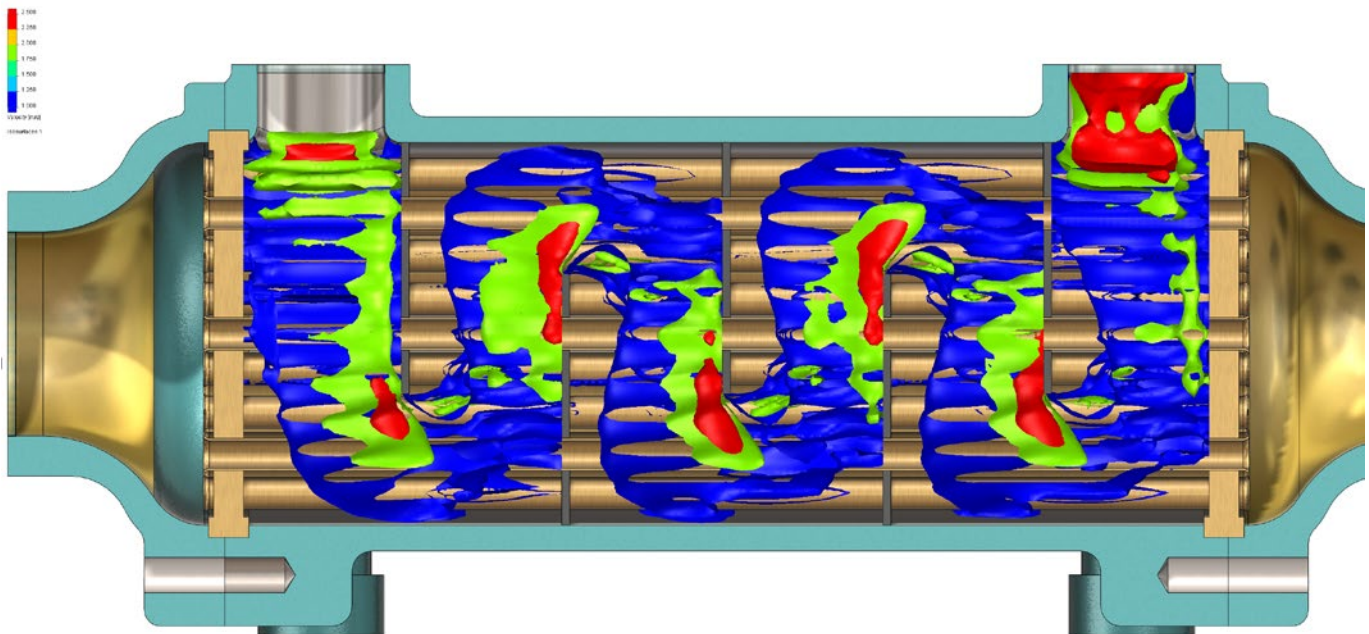

Using Computational Fluid Dynamics (CFD) is no longer relegated to the realm of the specialist. A new class of CFD analysis software, 'Concurrent CFD', is proving to be highly effective at performing heat transfer analysis, enabling mechanical engineers to accelerate key decisions at their workstations and without the need for CFD specialists. Embedded into the 3D CAD environment, this intuitive process allows designers to optimize a product during the design stages reducing manufacturing costs across a wide range of mechanical designs and systems.

Until recently, the commercial software available for CFD typically has been geared towards specialists, limiting its widespread use. In addition to being expensive, these tools have either been difficult, cumbersome or time-consuming to use. As a result, engineering analysis for applications such as heat transfer traditionally have been carried out by specialists in analysis departments, separate from mainstream design and development departments.

To test or verify their designs, mechanical engineers therefore had to rely on creating physical prototypes and testing them on a test rig. But this labor-intensive approach often led to incomplete results, limited to readings at discrete locations, making it difficult to thoroughly understand and characterize the underlying thermal behavior.

Fortunately, new tools have emerged that embed a complete range of flow analyses, including heat transfer simulation, within mainstream 3D CAD environments like the SOLIDWORKS® 3D design solution. SOLIDWORKS Flow Simulation engineering technology is aimed specifically at the mechanical design engineer. With SOLIDWORKS Flow Simulation there is no need to hire or train CFD specialists, outsource analysis to consultants, or conduct tests on expensive multiple physical prototypes.

Instead, a design engineer with standard training, in any size company, can use his or her existing knowledge to successfully perform heat transfer analyses, all within his familiar 3D CAD environment. SOLIDWORKS Flow Simulation can improve design productivity and may dramatically reduce the number of physical prototypes needed for testing. Equally important, it encourages engineers to explore many more ‘what-if’ scenarios to perfect their designs.

Certainly there will always be a few very demanding applications where more advanced CFD knowledge is needed to fine-tune the meshing and solver settings in order to converge to a solution. However, taking CFD out of the exclusive domain of specialists and bringing it into the mainstream with SOLIDWORKS Flow Simulation enables design engineers with no specific training in CFD to analyze problems in roughly 25 to 35 percent of the time it would take using traditional tools. This offers designers a fundamental breakthrough in design efficiency.

### HEAT TRANSFER ANALYSIS IN THE 3D CAD ENVIRONMENT

SOLIDWORKS mechanical design and SOLIDWORKS Flow Simulation CFD software provide a complete engineering environment for performing heat transfer evaluation by combining all the phases of analysis in one single package: from solid modelling, to problem set up, solving, results visualization, design optimization and reporting.

With SOLIDWORKS Flow Simulation designers can focus on analyzing, in detail, temperature distribution in the fluid and solid areas of their product. This includes the ability to analyze complex physical processes, such as heat conduction, heat convection, conjugated heat transfer between fluids, surrounding solid materials, radiation, joule heating and many more using ‘what-if’ scenarios, engineers can then quickly modify and optimize the design’s geometry within the 3D CAD tool, as shown in Figure 1, which illustrates the visualization of an oil cooler after simulation in SOLIDWORKS Flow Simulation.

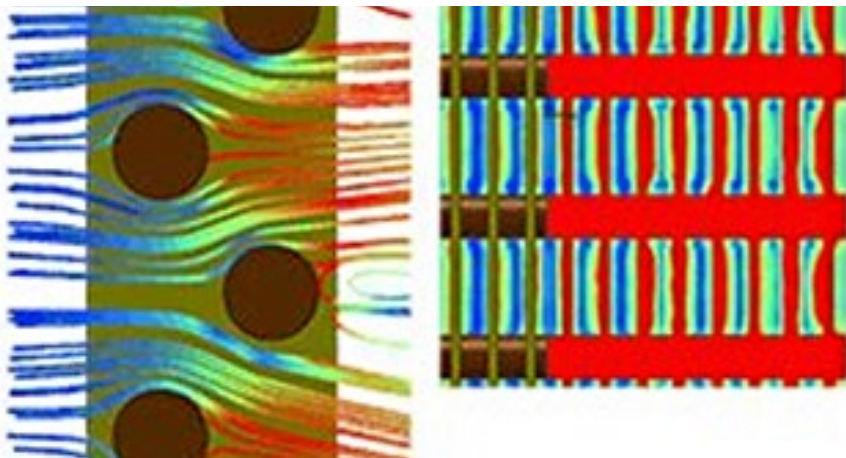

Figure 1: Visualization of heat transfer in an oil cooler after simulation in SOLIDWORKS Flow Simulation.

SOLIDWORKS Flow Simulation solves for all the three modes of heat transfer in 3D: conduction, convection and radiation which is why it can analyze a wide spectrum of applications. Typical temperature analysis applications include heat exchangers, injection molding device cooling, sterilization in food processing, solar towers, laser systems, brake design, and many others. In the case of a heat exchanger, not only can engineers look at the efficiency on the thermal side, but they will also be able to predict the pressure drop through the heat exchanger. Combining these parameters in one single model helps design a better product up front.

To use SOLIDWORKS Flow Simulation software, all the designer needs is knowledge of the MCAD system and the physics of the product. After installation of SOLIDWORKS Flow Simulation, all of the menus and commands necessary to run a full CFD flow analysis are created in the SOLIDWORKS menu system. This full interaction between SOLIDWORKS and SOLIDWORKS Flow Simulation makes it extremely easy to use. In fact, most designers report that they can use SOLIDWORKS Flow Simulation with less than 8 hours of training.

The starting point of any heat transfer analysis is to define the overall boundary conditions of the problem. SOLIDWORKS Flow Simulation offers a wizard to direct the setup, including the selection of material properties. SOLIDWORKS Flow Simulation allows a designer to take advantage of existing 3D CAD models for analysis, without having to export or import additional data, saving a significant amount of time and effort. The embedded SOLIDWORKS Flow Simulation toolset can use newly created or existing 3D CAD geometry and solid model information to simulate designs in real-world conditions.

Once a model is created, the model needs to be meshed. Developing a mesh is one of those skills that previously separated CFD specialists from mechanical engineers. With SOLIDWORKS Flow Simulation, meshes are created automatically, and in a matter of minutes, as opposed to many hours of tedious proportioning of regions and cells. SOLIDWORKS Flow Simulation actually creates an adaptive mesh that reduces the cell size, increasing the resolution of the analysis, to ensure more accurate simulation results in complex areas of the model, as shown in Figure 2.

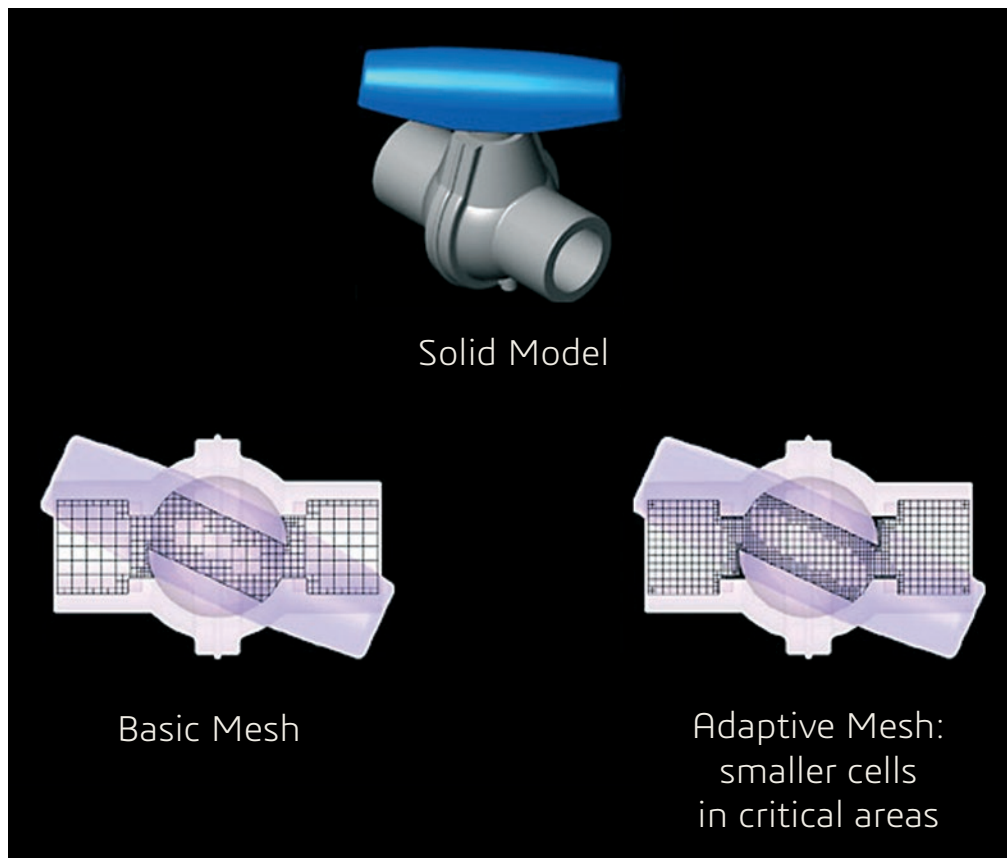

Figure 2: Using a rectangular adaptive mesh, Concurrent CFD tool SOLIDWORKS Flow Simulation can automatically adjust cell size to deliver better resolution anywhere it is needed.

## SOLVING ADVANCED HEAT TRANSFER CHALLENGES

When analyzing heat transfer, it is important to build a computational grid, or mesh, to capture the complex geometry of the system or device. While the mesh is simple in concept, it is the heart of complex CFD calculations. The surface of the device is mapped into tiny rectangular cells, each of which is split into solid and fluid volumes which are analyzed discretely. The process then develops a composite result that incorporates all of the cells.

SOLIDWORKS Flow Simulation provides extensive ability to visualize what is happening to a design's thermal dissipation, giving the engineer valuable insight that can guide design decisions. The visualization capabilities allow users to interrogate the design more thoroughly.

One way to examine the temperature field is to use a cut plot, which depicts the heat distribution on a plane through the model, as shown in Figure 3. A cut plot of results can be displayed with any results parameter and the representation can be created as a contour plot, isolines, or as vectors. It can also be created in any combination such as velocity magnitude, and velocity vectors. In addition to cut plots, a surface plot can be easily displayed for any particular face as well as automatically for the entire model.

Solving heat distribution problems is an iterative process. After seeing the initial analysis results, most designers want to modify their models to explore different scenarios. SOLIDWORKS Flow Simulation makes it easy to conduct these "what-if" analyses. Designers can explore design alternatives, detect design flaws, and optimize product performance before detailed designs or physical prototypes are created. This allows the design engineer to quickly and easily determine which designs have promise, and which designs are unlikely to be successful.

To examine alternatives, multiple clones of the solid model can be created in SOLIDWORKS Flow Simulation that automatically retain all analysis data such as heat sources and other boundary conditions. When the engineer modifies a solid model, it can be analyzed immediately without having to re-apply boundary conditions and material properties.

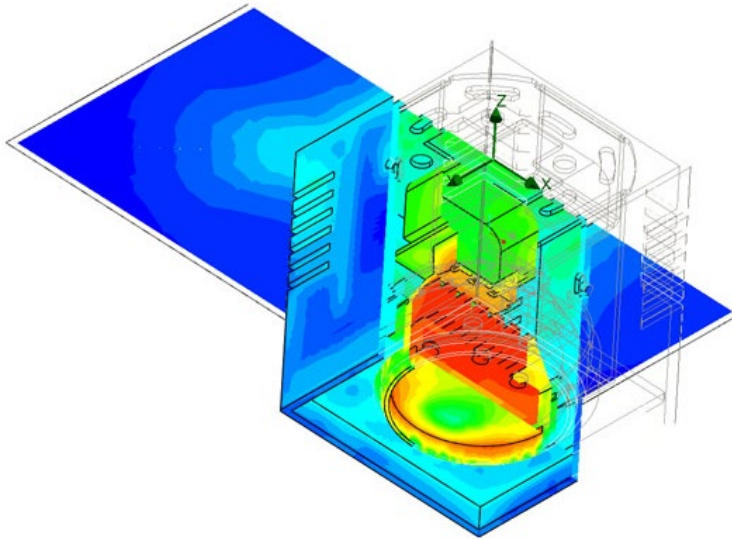

Figure 3: Temperature inside an LED lamp shown with a 50 percent slice.

With traditional CFD software, after each geometrical change it is necessary to recreate the mesh which usually involves time consuming manual intervention. In contrast, SOLIDWORKS Flow Simulation software operates immediately on the changed geometry, creating a new mesh automatically and working with the previously defined boundary conditions. Thus, the step from a changed geometry to running the solver and examining results is greatly accelerated. The software also aids in parametric analysis—for example, running an analysis multiple times with various vent sizes to determine the optimal design for heat distribution. In these ways, SOLIDWORKS Flow Simulation accelerates the iterative design process, allowing engineers to quickly and easily incorporate knowledge gained in an analysis into an improved design.

## VALIDATION AND VERIFICATION

SOLIDWORKS Flow Simulation provides robust verification capabilities for validating designs. Before releasing a new version of SOLIDWORKS Flow Simulation, R&D engineers validate the release with a suite of 300 tests. Based on this rigorous verification suite, SOLIDWORKS Flow Simulation offers 26 tutorial benchmark examples ready for immediate use.

For example, designers could use these benchmark examples to verify a known heat transfer benchmark for CFD: Simulate forced air cooling of plate fin heat sink placed in a wind tunnel.

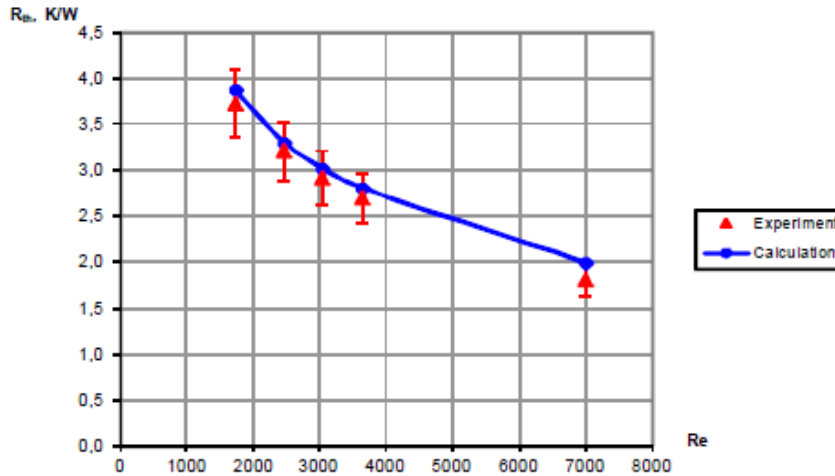

Figure 4: Thermal resistance of the Heat Sink versus Reynold number in comparison with the experimental data

## COMMUNICATION

Once the results are available, the product engineer needs to report his or her findings to others. SOLIDWORKS Flow Simulation is fully integrated with Microsoft® Word® and Excel®, allowing engineers to create report documents and collect important data in graphical form from any SOLIDWORKS Flow Simulation project. In addition it automatically creates Excel spreadsheets summarizing the outputs of an analysis; thus making the last step in any analysis—that of creating reports—effortless.

By using SOLIDWORKS Flow Simulation the product engineer can create a customized report, including the boundary conditions, the material properties, the mesh definition and the results plots, that is automatically saved in a word document. This report is a valuable project asset and is often archived by a data management system.

The next level of communication is to be able to communicate simulation results in 3D so it is more intuitive for all of the stakeholders and colleagues. The best way to communicate results in 3D is through eDrawings, SOLIDWORKS' 3D communication tool. Product Engineers can save their CFD results in 3D so their colleagues can review them on any device.

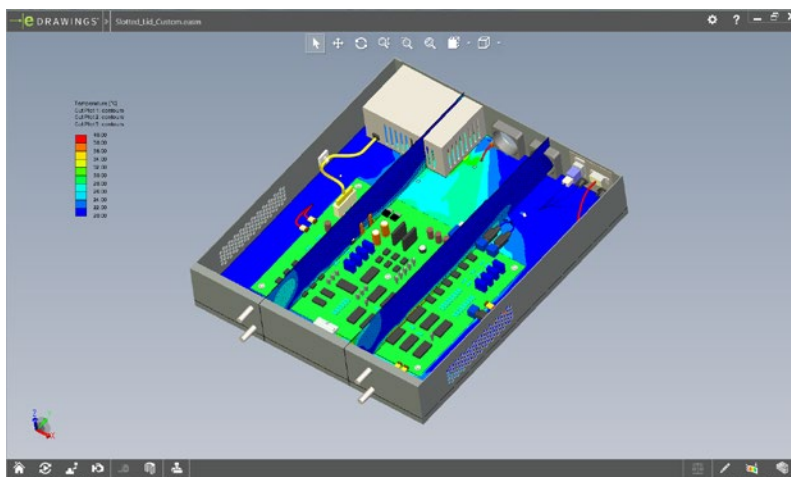

CFD Results communication in eDrawings

## REAL WORLD DESIGNERS AND SOLIDWORKS FLOW SIMULATION HEAT TRANSFER ANALYSIS

With SOLIDWORKS Flow Simulation, designers can focus on improving product performance and functionality without resorting to full time fluid dynamics specialists. The following are some real world examples that demonstrate the effectiveness of SOLIDWORKS Flow Simulation in helping designers meet tight deadlines, achieve higher quality results or keep costs to a minimum.

### Thermal simulation simplifies led luminaire development

Every form of electric lighting produces an unwanted by-product: heat. In the case of incandescent and fluorescent lighting, generations of engineers have developed ways to minimize and/or divert heat from luminaires and fixtures. However, LED lights appearing today, in growing quantity and variations, pose new and different challenges. Heat buildup can reduce an LED's light output and cause a color shift and at the same time, shorten the component's useful life. It has been said that thermal management is by far the most critical aspect of LED system design.

The key to successful LED system design is to transfer the active device's heat efficiently from its own PN junction to the ambient. The path involves both the printed circuit board, which mounts the LED, and the enclosure. The designer must confirm that housings and shrouds participate efficiently in carrying heat away from the LED.

The baseline for design validation, whether the product is a new luminaire or a replacement for an existing design, is of course a detailed understanding of the LED device's thermal behavior. This is also important when developing an LED lamp intended to retrofit into an existing fixture, as it is essential to match the thermal and cooling characteristics of the original equipment.

The process starts with the mechanical design of the luminaire. Figure 5 illustrates the outcome of this initial design step. The depicted system includes an integral connector (shown in yellow) attached to a lamp housing whose fins act as a heat sink. The connector plugs into a socket which may itself be designed to further disperse heat, acting as part of the cooling system for the lamp. However, in this particular system, the socket is simply a means of supporting and connecting the lamp. The light source is a power LED mounted on a metal-core PCB. In Figure 5, the lamp's lens is omitted to expose a more detailed perspective on the LED itself.

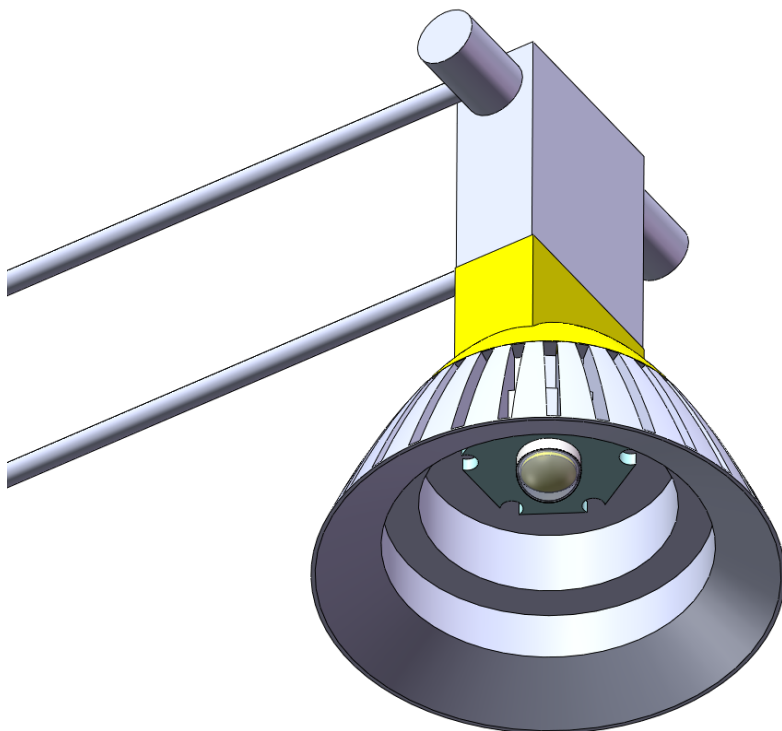

Figure 5: The 3D CAD representation of the LED luminaire

SOLIDWORKS Flow Simulation automatically models any internal cavities as fluid regions, a requirement for analysis. While the need for this step is more obvious for a pipe carrying a liquid, it is also necessary to predict the air flow through and around the luminaire.

The next step is to create the computational grid, or mesh, which SOLIDWORKS Flow Simulation does automatically. The mesh for the luminaire is shown in Figure 6.

Note that the cells in Figure 6 are not uniform in size. Those clustered around the LED are much smaller than those on the periphery of the housing. This feature found in SOLIDWORKS Flow Simulation provides higher resolution where it is most needed. Next the engineer must define boundary conditions, that is the operating parameters and limits that will be used in the calculations. Values for the external air temperature and the LED device heating power must be specified, and can be incremented over multiple iterations of the CFD analysis.

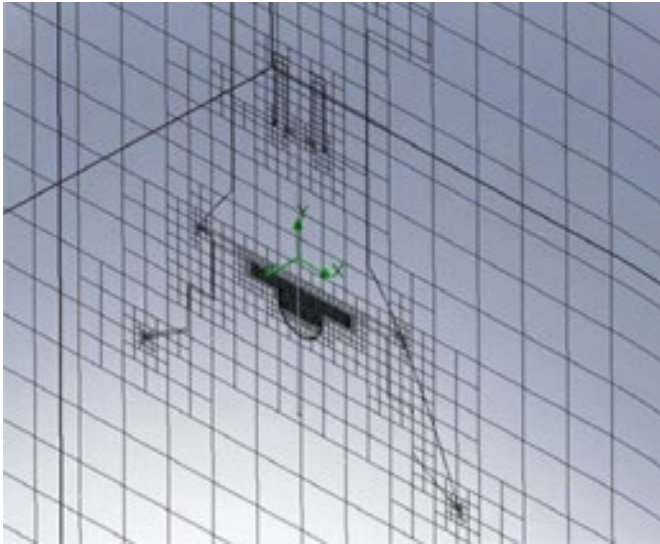

Figure 6: Computational mesh shown on a central slice through the lamp assembly.

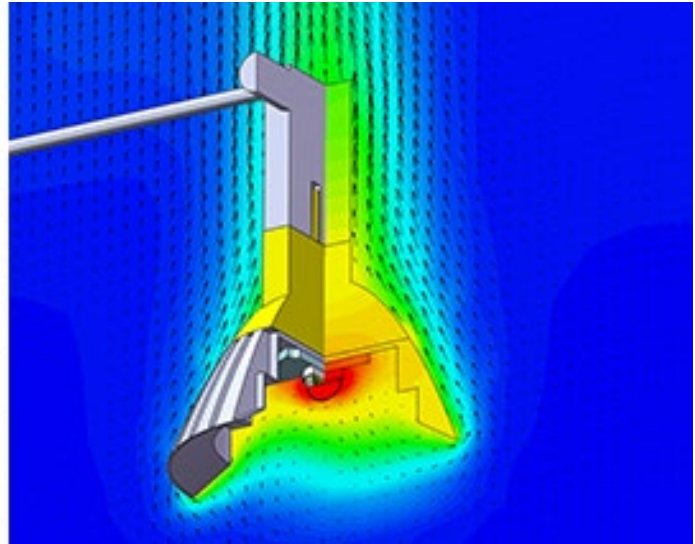

Figure 7: Temperatures on a 2D slice through the center of the lamp with vectors showing flow caused by natural convection over the outside of the lamp.

Figure 7 displays the outcome of the CFD operation on the cross-sectional slice. It not only shows the heat distribution across the physical elements of the lamp, but also the vectors for air flow due to convection over the exterior of the lamp. In this example, the 3D perspective has been restored for visual reference but the flow vectors pertain to the slice. In this view, the color spectrum goes from red (hottest) to blue (coolest), with gradations of orange and green between the two extremes.

Of course, the object of this exercise is to ensure that a proposed physical design will transport heat away from the LED source and conduct it safely toward the ambient environment. Figure 8 (overleaf), another Concurrent CFD view, provides an answer to this important question. In this view, weightless particles trace the air flow path, almost like infinitesimal dust motes. Here again the color spectrum reveals the heat distribution and in this image a color legend quantifies the values. Note the flow pattern: blue (cool) air comes up from below and is warmed to blue-green as it passes over the luminaire. Convection carries the warmed air up and away from the lamp. Is this sufficient dispersion for the lamp itself and any other housings that will be part of the final design? It is a question only the engineer can answer, but the Concurrent CFD analysis has provided the data necessary to support an informed judgment.

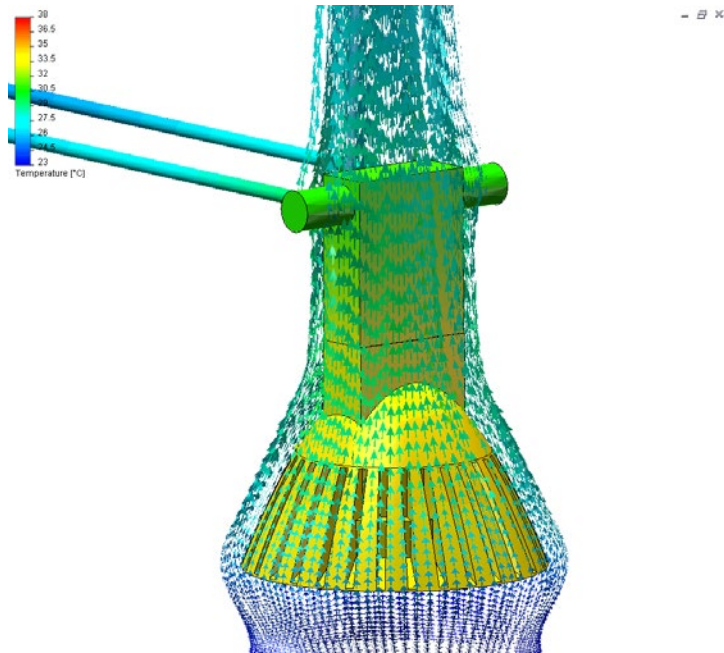

Figure 8: Particle tracks over the lamp, mounted horizontally and facing downwards, showing how the natural convection causes the air to flow smoothly over the exterior of the lamp housing. The thermal plume contracts as the flow accelerates above the lamp.

Figure 9 provides a little more detail. It is the “After” view of the LED and enclosure showing the heat gradients applied to the “Before” image shown earlier. Here again the legend offers quantitative details about the temperatures within the housing. This makes it easy to tell if, for example, touch temperatures are within safety limits.

Figure 9 provides a little more detail. It is the “After” view of the LED and enclosure showing the heat gradients applied to the “Before” image shown earlier. Here again the legend offers quantitative details about the temperatures within the housing. This makes it easy to tell if, for example, touch temperatures are within safety limits.

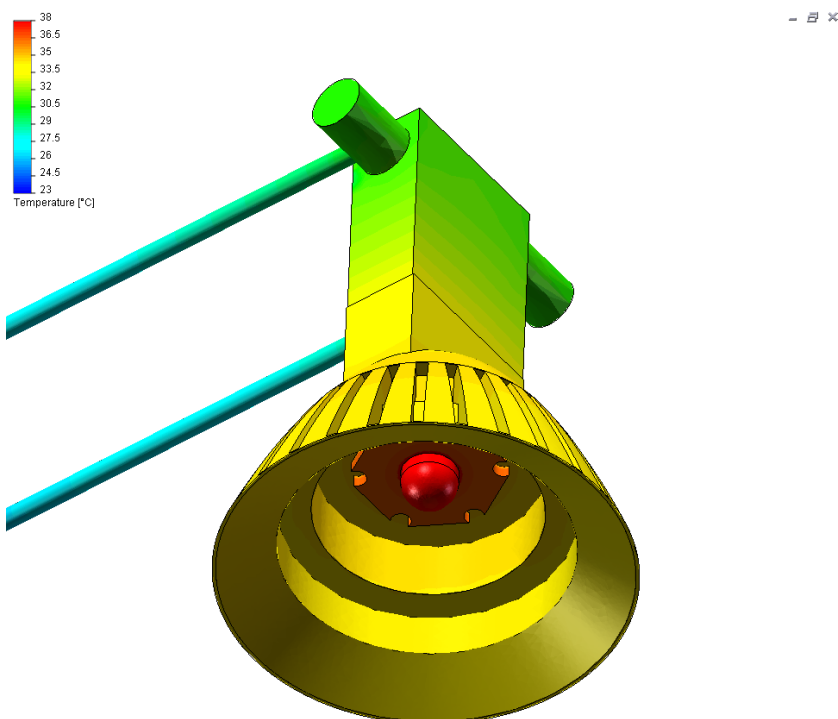

Figure 9: Predicted surface temperatures shown on the 3D CAD model

Using a Concurrent CFD tool such as SOLIDWORKS Flow Simulation flow simulation and analysis to refine design proposals can prove indispensable. It is far less costly than building and testing a succession of physical prototypes, and the automation built into Concurrent CFD means that preparation for the first evaluation cycle is brief and for every subsequent attempt, even faster. It is an environment that encourages experimentation until the design is truly optimized. For example, Concurrent CFD can be used to quickly determine the optimum number slots in the bell-shaped housing and the thickness of the metal between them to maximize the heat loss to the surrounding air.

## **OPTIMIZING COOLING FEATURES FOR ELECTRONICS PACKAGING WITH SOLIDWORKS FLOW SIMULATION**

Effective packaging of racked electronic systems involving multiple printed circuit boards and complex heat transfer challenges demands the expertise of a company like the POLYRACK Tech-Group, a leading provider of integrated packaging solutions for the electronics industry.

According to Development Manager Bernd Knab, a client approached POLYRACK about providing flow simulation consulting services. “When a customer requested that we conduct flow simulations of our packaging designs, we realized that flow analysis capabilities would become an increasingly important part of our operations,” Knab recounts. “We believed that the technology would enable us to save time, reduce costs, and improve performance through the visualization of the behavior within the laid-out construct.” In evaluating flow analysis systems, POLYRACK determined that a CAD-integrated package was preferable. “It’s better when the simulation takes place inside the CAD system,” Knab stresses. “It takes too much time when you have to write data to another format, and requires moving back and forth between the applications, and duplicating effort.” POLYRACK implemented SOLIDWORKS Flow Simulation CFD analysis software along with its Electronics Cooling Module to simulate heat transfer behavior in electronic systems.

With SOLIDWORKS Flow Simulation, POLYRACK can quickly simulate heat transfer behavior in packaging designs, 90 percent of which are customized for specific applications. These insights enable POLYRACK engineers to improve cooling performance while simultaneously saving time and reducing costs. For example, on a housing that included 10 different highly integrated boards, flow simulations demonstrated that the use of four large fans cooled the system more effectively than the eight small fans initially used in the design.

“The ability to simulate the effect of airflow characteristics with SOLIDWORKS Flow Simulation allows us to address heat transfer issues in software instead of through extensive and expensive prototyping,” Knab explains. “Without simulation capabilities, optimizing the cooling system for this racked configuration of 10 boards would have taken three months or longer. With SOLIDWORKS Flow Simulation, we completed the work in just two weeks.”

By simulating heat transfer phenomena and understanding how even small changes to packaging designs impact cooling system performance, POLYRACK can develop innovative approaches and reduce costly prototyping cycles. “The key is achieving the ideal amount of turbulence-free airflow over electronic components,” Knab points out. “With racked systems, you often have situations in which the board that is positioned near the fan receives most of the airflow, while the next board down in the rack isn’t getting enough.”

“With SOLIDWORKS Flow Simulation, we were able to recognize that by placing perforated metal plates in front of the fans and repositioning the PCBs, we could disperse the flow and provide homogeneous airflow throughout the system,” Knab continues. “This approach keeps air flowing at the same speed and pressure over each board. We were quite excited by this achievement because we may not have tried it without SOLIDWORKS Flow Simulation. In addition to optimizing the cooling system, SOLIDWORKS Flow Simulation helps us cut an average of two prototypes from each project.”

Because SOLIDWORKS Flow Simulation is integrated within SOLIDWORKS design software, POLYRACK can take advantage of design configurations to efficiently run heat transfer analyses on a range of different components, such as heat sinks. “We use configurations to run simulations on five different heat sink designs, for example, to determine which option will work best,” Knab notes. “We only have to define the problem once, and then can run all five simulations at once, which saves a lot of time.”

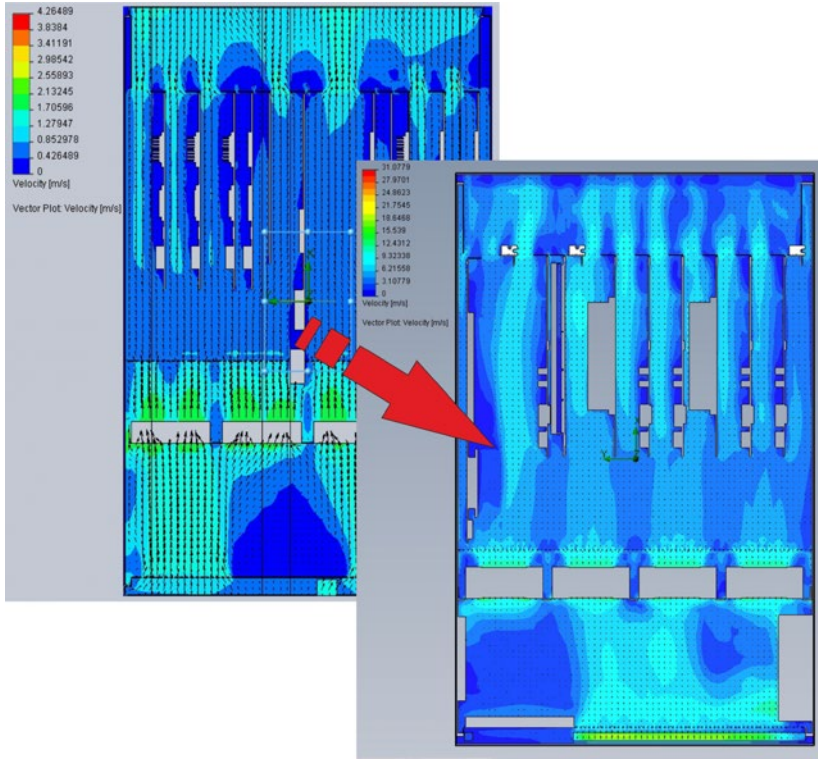

---

POLYRACK uses SOLIDWORKS Flow Simulation to optimize designs for racked electronic systems, producing better-performing designs without the need for extensive and expensive prototypes

Since implementing SOLIDWORKS Flow Simulation tools, POLYRACK has grown its flow simulation consulting from a single customer to a much more frequent task. “SOLIDWORKS Flow Simulation not only improves our productivity and efficiency, but also lets us tackle heat transfer challenges that we would not be able to resolve without it.”

## BURN IT, FLOOD IT, RESTORE IT— FIREPROOF, WATERPROOF HARD DRIVE ENGINEERED WITH SOLIDWORKS FLOW SIMULATION

ioSafe, Inc. set out to provide simple protection for the growing volume of valuable personal and business data by creating disaster-proof data storage devices for computers ranging from notebooks to enterprise data centers. Like an “aircraft black box for your data,” disaster-proof hardware presents both business and technical development challenges, according to ioSafe CEO Robb Moore.

The greatest technical hurdle that the company faced was inventing a way to cool the heat-generating electronics inside a perfectly insulated enclosure. ioSafe’s unique enclosure had to protect the drive from the temperature of a fire—around 1550°F—and remain waterproof, while retaining a venting-and-fan system for cooling operational electronics.

Using SOLIDWORKS and SOLIDWORKS Flow Simulation, ioSafe invented its unique hard drive by resolving the conflicting goals inherent in the design. The design begins with a thin, metalized, heat-conductive yet waterproof barrier that surrounds the hard drive. With this element, users can throw the hard drive in the ocean and submerge it for days without damage. Heat created by the hard drive passes through the waterproof barrier and into the cavity within the enclosure.

“SOLIDWORKS Flow Simulation is perfect for quickly optimizing the balance of air flow for cooling and outward steam flow during a fire,” Moore stresses. “We saved \$15,000 on product development resulting in a better optimized design by making virtual prototypes. By using simulation tools to optimize our air flow, we can achieve heat and water protection while maintaining vents that are appropriate for normal operation.”

The result of using SOLIDWORKS solution to design and optimize the ioSafe Solo was a 75 percent reduction in time-to-market through shorter development cycles.

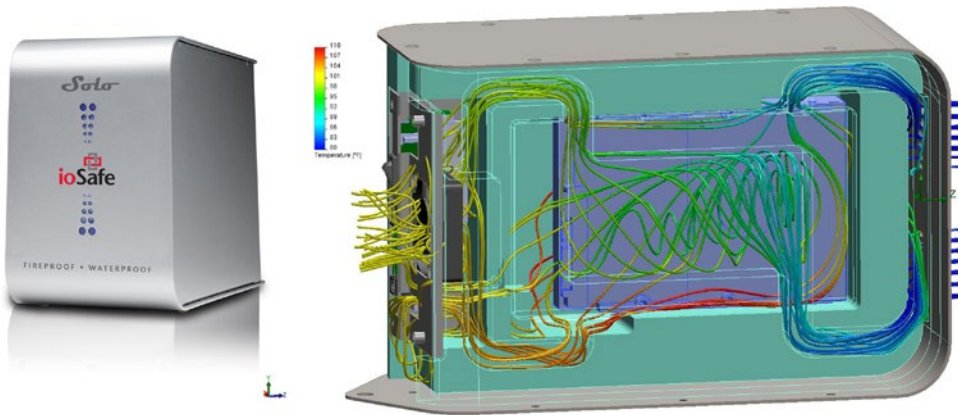

---

Using SOLIDWORKS Flow Simulation software, ioSafe optimized the balance of air flow for cooling and outward steam flow during a fire.

## BENEFITS OF CONCURRENT CFD

Concurrent CFD is a breakthrough technology that enables design engineers to conduct up-front Fluid Flow Analysis throughout the product's lifecycle. Using the familiar 3D CAD interface SOLIDWORKS, Concurrent CFD reduces design times by orders of magnitude compared to traditional methods and products and can reduce simulation time by as much as 65 to 75 percent. It also enables users to optimize product performance while reducing physical prototyping and development costs without time or material penalties.

### Traditional CFD

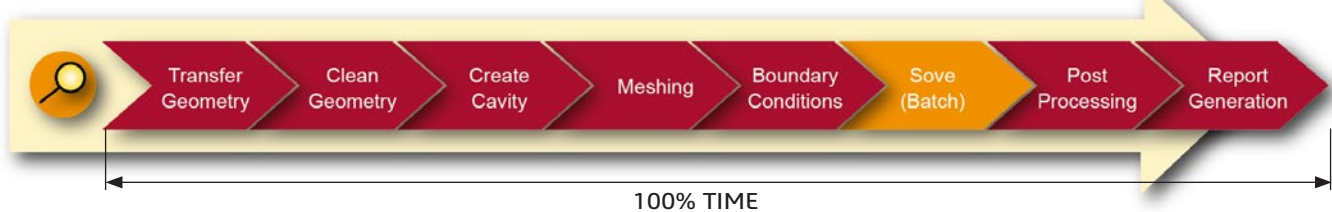

In traditional CFD, the model geometry is first exported from the CAD system. The geometry then needs to be re-imported into the user's CFD tool, meshed, solved, the results post-processed and finally reported back to the design team. The work is usually done by a specialist analysis group, or outsourced, so it is necessary for the design team to explain what needs to be done. By the time the results are in, the analysis model has become 'stale', as the design team often has moved on, making it difficult to act on the results.

### Upfront CFD

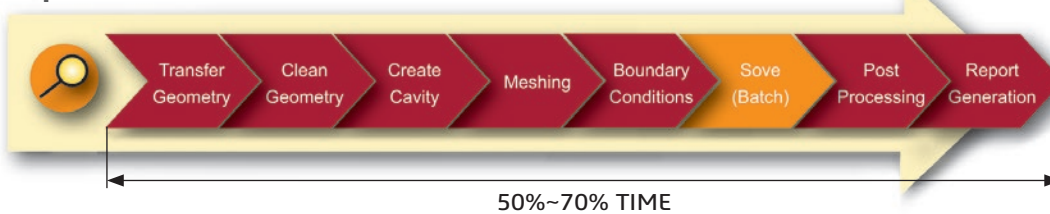

Upfront CFD attempts to improve this situation by streamlining the interface between the CAD and the CFD tool. Although this results in a much cleaner import of the geometry, the analysis is still performed outside of the CAD system. The frequent transfer from the CAD and CFD software can result in a degradation of information.

In addition, both of these approaches require the creation of a 'cavity' to represent the flow space. Most conventional CFD meshing tools work by meshing a solid, so there is no such thing as an empty space. To work around this limitation, the designer must create a solid object that represents the flow space and then use Boolean subtraction to remove the dummy model from an encapsulating solid. This is usually done in the CAD system and this inverted flow space then is transferred to the CFD system for meshing. Obviously, this is a labor-intensive process that can easily introduce errors into the design and analysis.

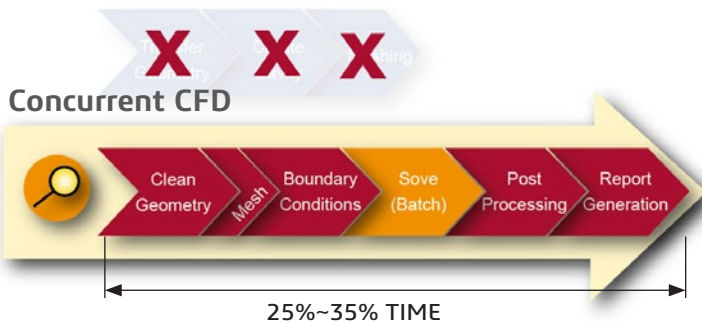

Concurrent CFD operates very differently. It is 3D CAD-embedded CFD so the work is done within the designer's familiar MCAD environment. Design changes necessary to achieve the desired product performance are made directly on the MCAD model, so the design is always up-to-date with the analysis. Preparing a model for analysis is very easy with SOLIDWORKS Flow Simulation. Unlike traditional CFD programs that require users to create additional solid parts to represent the fluid (empty) regions, SOLIDWORKS Flow Simulation automatically differentiates between the MCAD geometry for internal and external flows and automatically creates the fluid domain. As a result, engineers are able to concentrate on their project as opposed to creating extra geometry in their CAD system, minimizing confusion and saving them time and effort.

### ONE WAY FSI (FLUID-STRUCTURE INTERACTION) WITH SOLIDWORKS SIMULATION AND SOLIDWORKS FLOW SIMULATION

Understanding the interaction of deformable structure with surrounding fluid flow, called Fluid-structure interaction (FSI) is a crucial consideration in the design of many engineering systems. The success of many structural designs requires a deep understanding of both the thermal and mechanical response of the design as early as possible during the product development process. Temperature-dependent material properties, temperature gradient and thermally-induced deformation are important design considerations for a successful product.

Significant numbers of operational failures or performance issues are due to thermal-related problems. Indeed, heat can have a direct impact on mechanical structures by creating deformation and additional stress.

For example, when designing heat exchangers or electronic components, temperature changes need to be considered for the structural analysis as heat impact structural performance of the entire device. Such approach is called Thermal Stress Analysis. It refers to static analysis that includes the effect of temperature to assess thermal stress and thermal dilatation.

SOLIDWORKS Simulation, complete 3D CAD embedded solution, allows product engineers to seamlessly perform thermal-stress analysis with SOLIDWORKS Simulation and SOLIDWORKS Flow Simulation.

With SOLIDWORKS Simulation, designers can perform stress analysis to determine the response of parts and assemblies due to the effect of forces, pressures or temperatures. Loads can also be imported from Thermal Fluid Flow studies or from SOLIDWORKS Flow Simulation, to perform multiphysics analysis.

In this case, the temperature distribution on the walls of the model is automatically mapped onto the mechanical model and a stress analysis is performed in order to determine the resulting thermal stress and deformation.

The full integration of SOLIDWORKS Simulation and SOLIDWORKS Flow Simulation inside SOLIDWORKS 3D CAD ensure accuracy of the data as it eliminates data translation, conversion and recreation. Results from the thermal analysis are seamlessly applied to the structural analysis model with no manipulation, ensuring the highest level of accuracy.

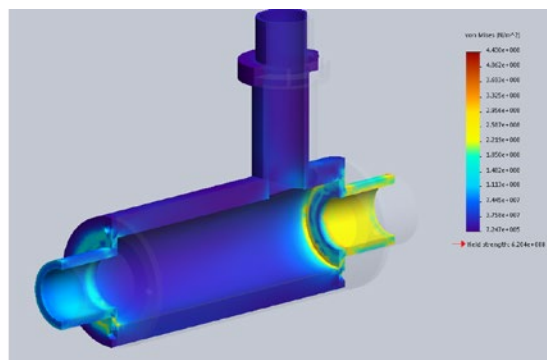
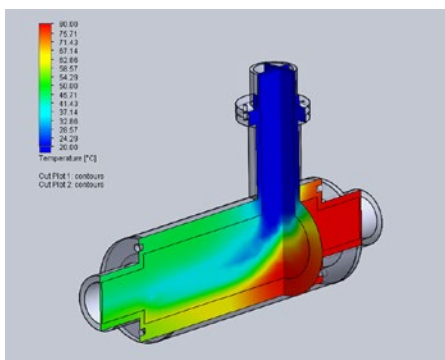

## CFD FOR ALL PRODUCT ENGINEERS

Thermal effects in engineering are often determined by a series of complex physical processes such as heat conduction, heat convection, conjugated heat transfer between fluids, surrounding solid materials, and radiation. Coupled with complex real world geometries, the need for accurate CFD prediction is critical to ensure product performance, and can be extremely difficult to estimate or calculate by hand.

SOLIDWORKS Flow Simulation identifies hot spots, quantifies thermal efficiency, and ensures uniform heat distribution for heat transfer devices, such as ovens, heat exchangers, as well as electronic cooling mechanisms. Further, SOLIDWORKS Flow Simulation works concurrent with product development process, and without the hassle of 'dirty geometry' and mesh generation of traditional CFD tools.

With a 20 year history, SOLIDWORKS Flow Simulation, with the concurrent engineering approach, gives every Product engineer the ability to evaluate how their designs will work in the real world; and analysis as you design allows you to make critical design decisions with confidence.

---

## Our 3DEXPERIENCE Platform powers our brand applications, serving 12 industries, and provides a rich portfolio of industry solution experiences.

Dassault Systèmes, the 3DEXPERIENCE Company, provides business and people with virtual universes to imagine sustainable innovations. Its world-leading solutions transform the way products are designed, produced, and supported. Dassault Systèmes' collaborative solutions foster social innovation, expanding possibilities for the virtual world to improve the real world. The group brings value to over 170,000 customers of all sizes in all industries in more than 140 countries. For more information, visit [www.3ds.com](http://www.3ds.com).



**3DEXPERIENCE**

### Corporate Headquarters

Dassault Systèmes  
10, rue Marcel Dassault  
CS 40501  
78946 Vélizy-Villacoublay Cedex  
France

### Americas

Dassault Systèmes SolidWorks Corporation  
175 Wyman Street  
Waltham, MA 02451 USA  
Phone: 1 800 693 9000  
Outside the US: +1 781 810 5011  
Email: [generalinfo@solidworks.com](mailto:generalinfo@solidworks.com)

### Asia-Pacific

Dassault Systèmes K.K.  
ThinkPark Tower  
2-1-1 Osaki, Shinagawa-ku,  
Tokyo 141-6020  
Japan