STREAMLINING THE DESIGN OF PACKAGING MACHINERY

Overview

To succeed as a designer of packaging machinery today, you must create highly innovative products and get them to market faster than your competitors. SolidWorks® software offers unique capabilities that can help you meet the challenge, enabling you to explore and test more design alternatives, improve quality, and streamline your entire development process.



Introduction

Today, the packaging machinery industry faces a unique set of challenges that stretches its engineering capabilities to the limits. Consumer goods producers are striving to evolve containers into new shapes to appeal to continually changing customer needs and tastes. Nearly every machine produced by a packaging machinery company is a one-of-a-kind creation designed to bring a package designer's creation to life, to increase production rates, or to lower costs.

To succeed in this business, you must be able to create new machines rapidly and easily. With SolidWorks software, you can reuse previous design work to create multiple variations of a product in a single document. Plus, you can develop and manage families of parts and models with different dimensions, components, properties, or other parameters. The goal, says a leading packaging machine designer, is to develop 80 to 90 percent of each new machine by using standard modules and components, and then use streamlined engineering processes to develop the other 10 to 20 percent in minimal time.

However, the need to move fast is not an excuse for making mistakes. When building a custom machine, you have to get it right the first time; and if you don't, you may have to do it all over again at your own expense. Getting it right means designing a machine that not only can perform well during acceptance testing, but also can operate 24 hours a day, 7 days a week, 365 days a year, for years and years—and under environmental conditions that can vary from a dusty bakery to a damp dairy products plant.

To succeed in this business, you must be able to create new machines rapidly and easily. With SolidWorks software, you can reuse previous design work to create multiple variations of a product in a single document.



Hartness International's DYNAC conveyor system intelligently regulates the flow of various products during packaging and packing.

SolidWorks Premium provides a unique set of tools that can meet these challenges. You can use subsystems and assemblies developed by your company, as well as those from industry standards groups and components producers. SolidWorks software also offers a wide range of design validation tools for evaluating a product prototype, so you can identify and fix problems before you even build your machine. The software provides links to computer-aided manufacturing (CAM), and generates the bill of materials needed for assembly and testing of the machine. Finally, you can utilize the 3D assembly model to quickly create project documentation.

Requests for Proposals (RFPs)

Experienced packaging industry professionals tell us that one of their greatest challenges today is taking advantage of existing designs to meet their customers' needs for one-of-a-kind machines at reasonable prices. With SolidWorks software, you can address this concern at the proposal stage, and then quickly deliver a competitive quote, while still having time to bid on other jobs.

Because SolidWorks Premium allows you to reuse 2D drawings and 3D models, you can quickly generate an accurate cost proposal based on your past completed jobs. Integrated SolidWorks product data management (PDM) software securely archives and organizes multiple versions of previous projects. As a result, you can quickly search both 2D and 3D designs to find a relative baseline. Once the correct job is found, the PDM software automates the duplication of projects to quickly get you started on the new proposal.

With SolidWorks eDrawings® software, you can further streamline the proposal process by improving communications with your customers. You can deliver 2D drawings and 3D models to your customers, who can view, print, and review them with free viewer software. In addition to panning and rotating the model for viewing at every angle, your customers can also provide feedback by using intuitive markup tools. By providing animations that allow your customers to view the virtual machine in operation, you will demonstrate why your proposal is superior to others. eDrawings is the best way to engage your customers in the proposal process, and to differentiate your company from the competition.

Component selection

Anywhere between 20 and 70 percent of the content of a typical packaging machine consists of purchased components, such as motors, drives, bearings, and hydraulic cylinders. As a result, you are forced to redesign purchased and commonly used components with each project. However, with the SolidWorks Design Library, you can access a wide range of standard, vendor-specific, and internal company design libraries at one central location. To add new parts to your machine, simply drag and drop them into your design.

SolidWorks Toolbox incorporates ANSI, ISO, DIN, and JIS standard parts, such as fasteners, bearings, retaining rings, and gears. You can drag and drop bolts, nuts, and washers from the SolidWorks Toolbox and snap them into place on the assembly. Smart Part Technology automatically sizes and positions the components according to where and how they interface in the assembly.

In the past, you were often forced to use out-of-date paper catalogs as a reference for redrawing purchased components. Now, 3D ContentCentral® gives you easy access to 3D CAD models from leading components manufacturers, such as SMC, Boston Gear, Danaher Motion, Bimba, and Warner Electric Break. You can browse product categories to view competitive products, configure suppliers' parts to meet your requirements, and drag and drop their products right into your design—saving time and improving accuracy. The SolidWorks Design Library consists of features, parts, and assemblies that can be dragged into new machine designs, thereby promoting reuse and providing a platform to develop company standards.

SolidWorks product data management software automates the duplication of projects to quickly get you started on the new proposal.

To add new parts to your machine, simply drag and drop them into your design.

Mechanical design

When every machine you build is one-of-a-kind, you need to design it right before it goes into production. SolidWorks Premium provides a wide range of virtual prototyping tools that can help you correctly identify and solve software problems up front. In addition to viewing the components, subassemblies, and the complete machine from all angles, you can examine internal components at any stage of the design process. Plus, you can move components through their full range of motion, automatically identifying clearances and detecting interferences. With the ability to find problems early in the process, you can quickly communicate design intent to your customers, Manufacturing, and Maintenance.

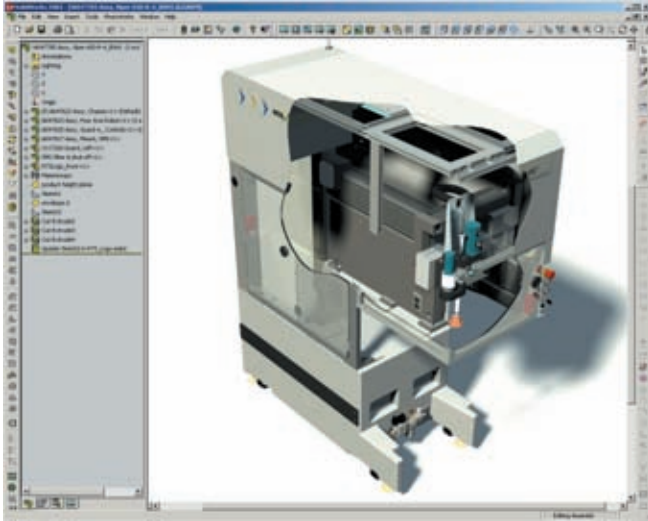

RTS used the dynamic assembly capabilities in SolidWorks software to identify and resolve component interference and collision problems on the Viper 650.

With the production-level drawing and detailing capabilities of SolidWorks software, you can quickly and accurately develop drawings from the 3D design—including the automatic generation of orthographic, section, and detail views. Any change to the machine is accurately reflected in all project drawings automatically.

SolidWorks software provides unparalleled performance in modeling machines with tens of thousands of components. With top-down design, you can tie together interrelated components; so if one changes, the related components will also change. You can use this powerful feature to take full advantage of the assembly model. For example, you can use 2D layout sketches as assembly skeletons to control large, complex assemblies. You might use the 2D skeleton to size a pick-and-place unit that is associated with the linkage and other components. When you change the skeleton, the linkage and other components will automatically reflect the correct dimensions.

SolidWorks Premium provides you with a wide array of process-specific tools. For weldment design, you can use an intuitive layout approach to quickly capture design intent. By utilizing weldbeads, gussets, caps, and cut lists, you can complete your weldment design and documentation. SolidWorks software also includes powerful and intuitive tools for creating advanced sheet-metal designs in folded and flat states. The software automatically applies all sheet-metal properties, such as metal thickness, bend radius, and bend relief, and automates the process of creating flanges, tabs, lofted bends, flat patterns, normal cuts, corner cuts, normal treatments, hems, jogs, and more.

In addition to viewing the components, subassemblies, and the complete machine from all angles, you can examine internal components at any stage of the design process.

With SolidWorks software, you have the flexibility to create multiple versions of parts, assemblies, and drawings in a single document, thereby maximizing the opportunities for reuse. For instance, you can create machine modules with different lengths of steel channel sections to make up different sizes of machine bases or supports. You can also explore various “what if” scenarios by turning on or off different configurations of a part or an assembly and using the analysis tools found in SolidWorks software to evaluate their performance.

SolidWorks Premium includes routing functionality that speeds up the design of pipe, tubing, and electrical routes by providing drag-and-drop placement, automatic sizing of parts or assemblies, copying and mirroring of routes, and autoinsertion of piping bends and elbows. By designing your routes in the assembly environment, you can quickly create multiple iterations to achieve the best results and avoid potential assembly problems. SolidWorks software also automatically generates manufacturing drawings and material lists of routed components.

Typically, packaging machinery companies must guarantee that their one-of-a-kind products can withstand a cumbersome duty cycle. With SolidWorks Simulation— included in SolidWorks Premium—you can determine the stress, strain, deformed shape, and displacement of components under operation, thereby avoiding field failures. This tool can quickly identify weaknesses in the initial design. You can generate new computer models quickly and inexpensively to solve problems that would otherwise not be discovered until the testing phase or, worse yet, in the customer’s plant. By determining the exact duty cycle of components, you can use lighter-duty parts or remove unnecessary material to reduce the cost and weight of the machine.

SolidWorks Motion goes one step further by simulating the dynamic operation of the machine or any subsystem. Constraints and contacts are automatically created from the assembly, and forces and actuators are easily added to the machine model. Since you never have to leave the SolidWorks software environment, you don’t need to transfer geometry or learn a new interface. With the model created, you can perform dynamic simulations that allow you to fully understand the kinematics and dynamics of the design. You can size motors and actuators, determine power consumption, lay out linkages, optimize CAMs, understand gear drives, size springs and dampers, determine how contacting parts behave, and generate operating loads for use in SolidWorks Simulation.

By designing your routes in the assembly environment, you can quickly create multiple iterations to achieve the best results and avoid potential assembly problems.



You can use the simulation capabilities of SolidWorks software to quickly identify problems in your initial design.

Assembly and testing

As the design is generated, SolidWorks software automatically maintains the bill of materials, and can export it as an Excel spreadsheet or in other formats for import into your material requirements planning (MRP) system. This information will save time and help you to avoid errors during the purchasing process. The software tracks a wide range of information, such as the manufacturer of purchased components, model number, size, and weight. You can generate a single bill of materials for multiple projects with numerous parts, quantities, and configurations in order to speed the transition to manufacturing and purchase in greater quantities at lower prices.

Engineering changes typically occur at a rapid rate during the assembly and testing phase. With SolidWorks software, you can avoid costly mistakes since changes made anywhere in the process automatically update all product documentation, including parts, assemblies, and drawings.

By partnering with industry-leading CAM software companies, Dassault Systèmes SolidWorks Corp. can deliver a variety of powerful CNC programming solutions for milling, turning, and electronic discharge machining. Certified CAM solutions read native SolidWorks software geometry and are fully associative, ensuring that design changes are reflected in the CNC program. Certified Gold Solutions also provide single-window integration with the SolidWorks software design model, enabling the CNC program to be generated within the familiar SolidWorks software environment.

The SolidWorks Manufacturing Network simplifies the process of finding design and manufacturing service providers that use SolidWorks software and can work with native SolidWorks software files, so you don't need to convert or re-create design files. Instead, you can easily find the right supplier on the network by browsing through 21 categories—ranging from a machine shop to an outside design firm—or by searching on keywords.

Project documentation

With 2D CAD tools, you end up spending a lot of time re-creating portions of the design in order to document the machine. But with SolidWorks software, you can easily use the 3D assembly to quickly create production-level 2D drawings. By simply drawing a line, you can create section views. Then the SolidWorks software will section the assembly and automatically produce the drawing. You can quickly create exploded views that describe how to maintain the machine by first arranging components in 3D, and then selecting areas of interest to define 2D detailed drawing views. Plus, you can easily annotate these views with balloons that are keyed to the bill of materials to highlight components of interest.

You can generate a single bill of materials for multiple projects with numerous parts, quantities, and configurations.

You can quickly create exploded views that describe how to maintain the machine by first arranging components in 3D, and then selecting the areas of interest to define the 2D detailed drawing views.

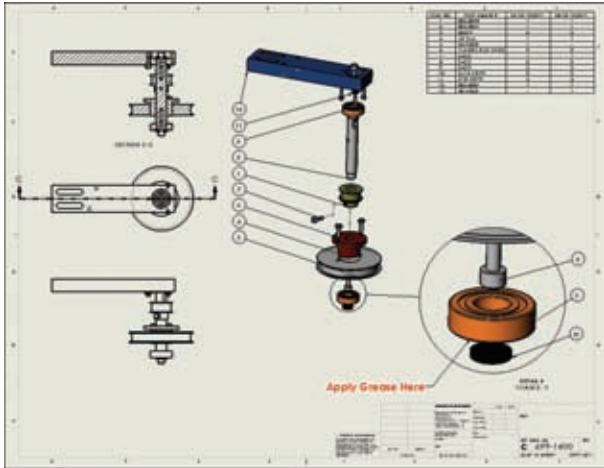

SolidWorks software makes it easy to create maintenance instruction documents using 3D designs.

SolidWorks eDrawings software allows you to distribute 2D and 3D drawings to customers or others who can view them without having to install any software. With eDrawings files, machine designers can securely show their drawings to customers and suppliers without revealing sensitive design data. Recipients are able to view and interrogate the drawings with enough detail to quickly understand any machine maintenance instructions.

The animation capability in SolidWorks software goes one step further by providing the ability to create animations easily from parts and assembly models. The software captures assembly motion to demonstrate how the moving parts of the packaging machine operate. You can explode or collapse the assembly to show how it fits together. You can fly the animation around the machine or subsystem, or revolve it 360 degrees on a turntable to view it from every angle. When you need to deliver maintenance documentation to your customers, both SolidWorks software animation and SolidWorks eDrawings will provide added value.

Conclusion

SolidWorks Premium can help you dramatically improve the design of packaging machinery. With the ability to easily and quickly reuse past designs, components built by suppliers, and standards-driven parts, you'll save time and money. SolidWorks software's advanced modeling capabilities not only streamline the design process, but also help you and your customers visualize the design at every stage. Plus, a powerful array of integrated analysis tools lets you validate your initial design by quickly creating software prototypes—so you get it right the first time. With SolidWorks Premium, you can simplify the transition from design to manufacturing, while providing your customers with a higher level of documentation than ever before possible.

Dassault Systèmes
SolidWorks Corp.
300 Baker Avenue
Concord, MA 01742 USA
Phone: 1 800 693 9000
Outside the US: +1 978 371 5011
Email: info@solidworks.com
www.solidworks.com

