

BERMO INC.

Improving die design throughput and accuracy with SolidWorks software and 3D QuickTools



Bermo Inc.'s 600-ton stamping press

If it starts out as sheet metal, Bermo Inc. makes it, whether it's a staircase leading up to a Kenworth cab, a fan shroud for a Detroit auto maker, or any of a multitude of stamped, bent, punched, pressed, and extruded parts that go into Toro mowers, Polaris snowmobiles, or John Deere tractors.

The \$26 million Circle Pines, Minnesota, company bids competitively for this work, and profits when it can perform more efficiently and intelligently than its global competitors. In 2006, these imperatives led the company to adopt 3D CAD software from Dassault Systèmes SolidWorks Corp. and 3D tool & die design software from 3D QuickTools Ltd.

These tools help Bermo deal with the complexity in manufacturing parts as ostensibly simple as, say, a bracket for a snowmobile suspension system. Although the order comes to Bermo as a 3D CAD model, the physical part will start out as a length of rolled sheet metal—steel, aluminum, brass, or copper—run progressively through a series of dies in massive presses applying up to 600 tons of force on the Bermo factory floor.

The many facets of unfolding designs

Manufacturing engineers like Bermo's Jay Suhsen need a way to virtually unfold the design into a strip that can be cut from the rolled sheet metal. They need to lay out the strip in a way that makes the most economical use of materials; create the tooling that will precisely bend, punch, stamp, extrude and cut the piece; and determine the optimum progression of processes to create the finished part.

In the old days, much of this work was done from two-dimensional plans, intensive hand calculations, and a heavy dose of what Suhsen terms "black magic." None of it was straightforward. What looks to a consumer like a simple bend, for example, is a process that consumes space from adjacent planes, affecting .002-inch tolerances and distorting many part features.

- Company performance improved significantly
- Getting the design right the first time saves costly re-design and reduced delays in the manufacturing process
- Software handles the "busy work" enabling engineers to focus on engineering
- SolidWorks and 3DQuickTools integration enabled Bermo to easily understand and use both applications



"You can't afford to stack up a lot of errors," says Suhsen. "The flat blank needs to be very precise, and we don't have time to develop multiple prototypes."

Getting the flat blank right used to take an hour and a half, and the strip layout two to three hours for a typical straightforward part. It required a lot of checking afterward, and still allowed human error. Since there is no time for prototypes, Bermo would start production and check the first few parts. If they were okay, the press would keep running. If not, it was time to redesign the part and hopefully cut losses.

"Today, with SolidWorks® and 3DQuickPress® software, the flat blank can take less than a minute, the strip layout under an hour, and there are no errors," says Suhsen. "3DQuickPress takes a part model designed in SolidWorks software and virtually unfolds it on the computer screen into the flat blank. It unfolds models that most CAD programs couldn't. We don't spend time checking and double-checking any more because we haven't found a single case where 3DQuickPress unfolding has been wrong. It's just right the first time."

Economy matters

The flat blank is only step one. The next step is virtually positioning multiple flat blanks on the unrolled sheet, so they make the best use of the expensive material. Bad decisions here can cost thousands of dollars over a high-volume part run. Consequently, Bermo uses 3DQuickPress's optimize command to position the flat blank in the strip in the most economical position possible, often automatically "nesting" parts—think of the yin yang symbol – to minimize waste. This spares Suhsen and his colleagues time, tedium, trial, and error. "We're trying to pinch every penny to beat competitors, and this is one effective way to do it," he says. "3DQuickPress is always right."

For small quantities, a run of 1,200 parts or fewer, Bermo sends unfolded part files to any of five 4,000-watt lasers using SigmaNEST® programming software. Because SolidWorks software interoperates seamlessly with SigmaNEST, Bermo no longer has to convert files to neutral formats, which can introduce stray files and, consequently, more chance for error.

For high-volume runs of up to 100,000 or more parts, the first step after strip layout and optimization is deciding the progression of stamping, pressing, piercing, punching, and cutting that the strip will undergo. Most strips undergo eight to 12 separate processes from blank sheet metal to finished part. 3DQuickPress automates this decision-making, helping manufacturing engineers plan the progression from die station to die station, with each action preserved in subsequent stations in the 3DQuickPress application. "If three holes were punched in station 3, those holes will be present in station 12," says Suhsen. "You don't have to draw the holes over and over at each station. With 3DQuickPress, I can simply drag and drop functions to the station where I think it works best. This is where the expertise of the engineer really matters, and 3DQuickPress handles all the busy work."

At this stage, the engineer submits the strip and die progression to a rigorous team-wide design review. "The strip is the roadmap to success," Suhsen says. "Put a bunch of people in a room scrutinizing it, and you come out of that room with a lot of good ideas. It used to take all day to incorporate their recommendations. Now I just drag and drop to incorporate their ideas."

"AS DESIGNERS, WE'RE ABLE TO DO A LARGER VOLUME OF WORK AND ELIMINATE HUMAN ERROR. AS A COMPANY, WE'RE ALSO MAKING BETTER USE OF OUR MATERIALS. THE OVERALL RESULT IS A SIGNIFICANT IMPROVEMENT IN PERFORMANCE."

Jay Suhsen
Manufacturing Engineer
Bermo, Inc.

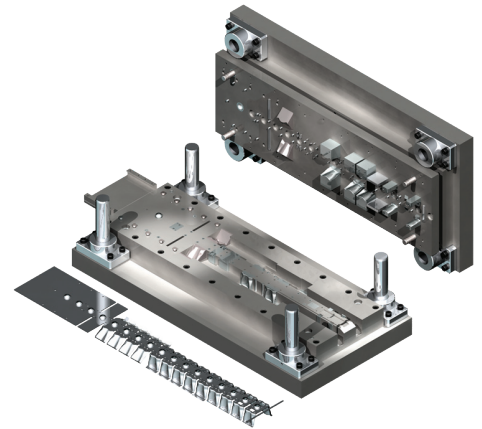

Bermo Inc. die design

Smart tools for intelligent die design

Finally, the engineer creates the tooling and dies to execute the die progression, selecting from a vast production-ready library (PRL) in 3DQuickPress populated at Bermo by Dayton tools. "They're not just dumb library parts," says Suhsen. "3DQuickPress grows selected tools to the size of the sketch and places them in the correct z (vertical) axis. Tooling selection associates with the original strip design as well as its place in the die progression. Click on a hole, for example, and the software automatically defines the correct punch, dictating the right part number and length. When the punch and die designs are complete, the SolidWorks software/3DQuickPress data flows to the CNC-driven machines that cut tooling bases from two-inch-thick metal plates. These plates are then fitted with selected tools and precision-mounted on the press."

When Bermo is making a part with especially complex drawn surfaces, Suhsen's team uses another 3D QuickTools application. 3DQuickForm® unfolds complex drawn surfaces such as the snowmobile seatback mount Bermo recently made. 3DQuickForm calculates curves, performs finite element analysis on the part, and assists the designer in determining the necessary tooling. "It's pretty amazing when egg-shaped holes on the screen become perfect circles after the part is formed," Suhsen says.

In addition to automating strip, tool and die development, 3DQuickPress adds specialized design capabilities to the SolidWorks software environment, such as the ability to create a slot, set electrical discharge machining start holes, close gaps, and replace splines—all automatically.

"SolidWorks and 3D QuickTools software have a symbiotic, seamless relationship," according to Suhsen. "They have similar menus and feature managers, making it easy to run both at the same time and leverage existing knowledge from one application to the other. With 3D models being so complex these days, we need 3DQuickPress more than ever just to develop the strip. Before, if you couldn't draw a product on paper, you couldn't propose the product, so there was a limit to the complexity of part designs we unfolded. With the third dimension and solid modeling, things have gotten far too complex for the manual unfolding of parts."

As complexity soars, so do the benefits of using the right software.

"As designers, we're able to do a larger volume of work and eliminate human error," he says. "As a company, we're also making better use of our materials. The overall result is a significant improvement in performance. That said, we're still in the infancy stage. We don't think we're as good as we're going to get. We're still learning what these tools can do for us."

Bermo relies on authorized SolidWorks software reseller Symmetry Solutions Inc. and Strategic Technology Solutions (STS) for ongoing software training, implementation, and support.

For more information, visit:

www.3dquicktools.com
www.bermo.com
www.callsts.com
www.solidworks.com
www.symmsolutions.com

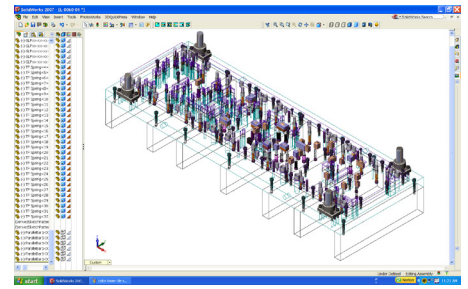

Wireframe lower die set



Bermo Inc.
4501 Ball Road NE
Circle Pines, MN 55014
Phone: +1 763-786-7676
www.bermo.com



Dassault Systèmes
SolidWorks Corp.
300 Baker Avenue
Concord, MA 01742 USA
Phone: 1 800 693 9000
Outside the US: +1 978 371 5011
Email: info@solidworks.com
www.solidworks.com

